

3-Port Atmospherically Referenced

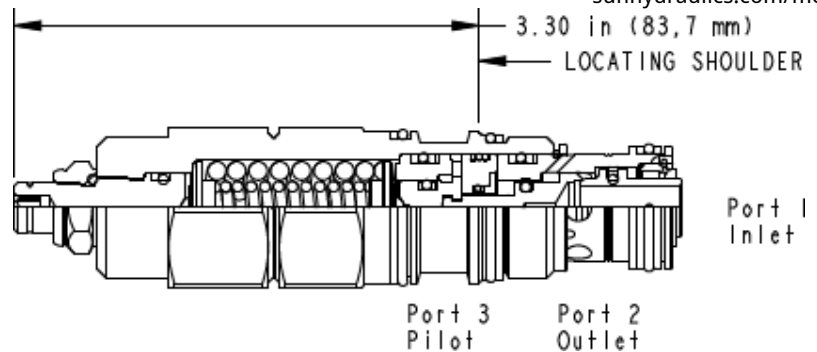

## CONFIGURATION

<b>L</b>	Control	Standard Screw Adjustment
<b>H</b>	Functional Setting Range	1000 - 4000 psi (70 - 280 bar), 3000 psi (210 bar) Standard Setting
<b>N</b>	Seal Material	Buna-N
<b>(none)</b> Material/Coating		

Atmospherically vented counterbalance valves with pilot assist are meant to control an overrunning load. The check valve allows free flow from the directional valve (port 2) to the load (port 1) while a direct-acting, pilot-assisted relief valve controls flow from port 1 to port 2. Pilot assist at port 3 lowers the effective setting of the relief valve at a rate determined by the pilot ratio. Backpressure at port 2 does not affect the valve setting because the spring chamber is atmospherically referenced.

Other names for this valve include motion control valve and over-center valve.

## TECHNICAL DATA

NOTE: DATA MAY VARY BY CONFIGURATION. SEE CONFIGURATION SECTION.

Pilot Ratio	3:1
Maximum Recommended Load Pressure at Maximum Setting	215 bar
Maximum Setting	280 bar
Factory Pressure Settings Established at	30 cc/min.
Maximum Valve Leakage at Reseat	0,3 cc/min.
Check Cracking Pressure	1,7 bar
Adjustment - No. of CCW Turns from Min. to Max. Setting	5
Reseat	>85% of setting
Locknut Hex Size	15 mm
Locknut Torque	9 - 10 Nm
Seal kit - Cartridge	Buna: 990302007
Seal kit - Cartridge	Viton: 990302006

## CONFIGURATION OPTIONS

Model Code Example: CAEAArray

CONTROL	(L) FUNCTIONAL SETTING RANGE (H)	SEAL MATERIAL	(N) MATERIAL/COATING
<b>L</b> Standard Screw Adjustment	<b>H</b> 1000 - 4000 psi (70 - 280 bar), 3000 psi (210 bar) Standard Setting	<b>N</b> Buna-N	Standard Material/Coating
<b>C</b> Tamper Resistant - Factory Set	<b>I</b> 400 - 1500 psi (28 - 105 bar), 1000 psi (70 bar) Standard Setting	<b>V</b> Viton	/AP Stainless Steel, Passivated /LH Mild Steel, Zinc-Nickel